



# ECO-WIZ™

## Dry System Food Waste Composter

(Eco-Wiz Composter EW DCP)



The “ECO-WIZ™” is a totally self-contained, continual feed, organic waste disposal system designed to biologically convert solid food waste materials into compost. Composting your organic wastes not only keeps them out of the landfills, but when applied back into your

lawn or garden, it also improve the health of your soil. Nutrients were stored in the decaying organic matter. Compost holds these nutrients in a form that is easily absorbed by plant roots.

The primary function of the “ECO-WIZ™” is to accelerate the natural decomposition process by maintaining optimal levels of aeration, moisture, temperature. Under these manipulated environment, our unique microorganisms can safely decompose any food waste at a much faster rate than natural decomposition, without soil and ground water contamination. The “ECO-WIZ™” can safely and quickly decompose any kind of food waste including: vegetable/fruit scraps, raw and cooked meats, fishes, poultries and dairy products.

### Standard Features

---

- Stainless steel cabinet for easy cleaning and long life
- Built in air filtration device
- Auto stop when top lid opens
- Auto start when top lid closes
- Warning light and alarm when chopper lid opens
- Protected control panel
- Easy installation (No water supply & Drainage)
- Quiet, Clean, Cost Effective, Sanitary
- Low cost operation and hassle free maintenance
- Long lasting formula (1 year)
- Fully automated operation

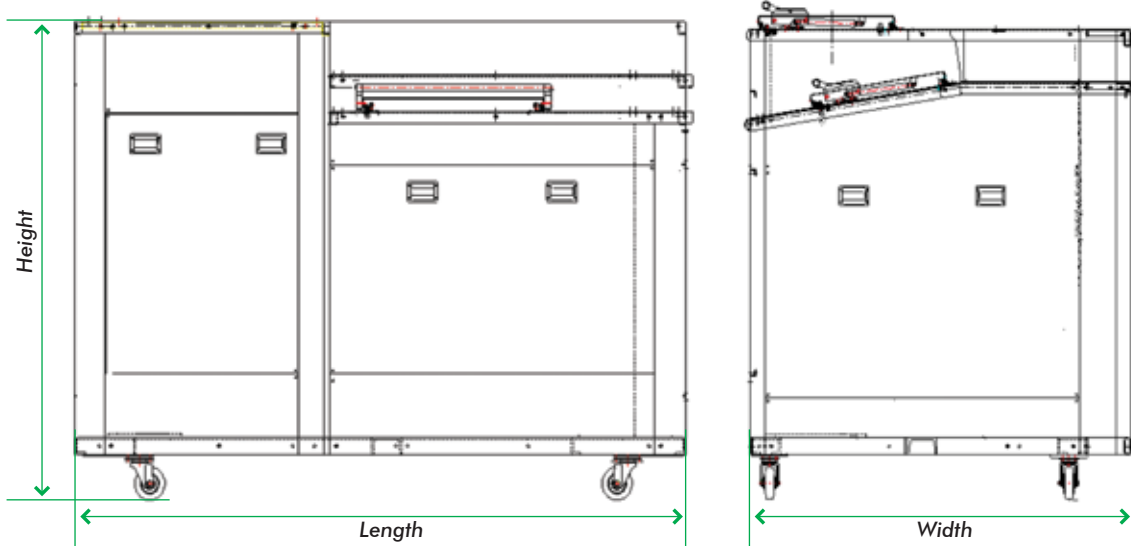

## Dimensions

MODEL NUMBER	CAPACITY / DAY Kg (lbs)	DIMENSIONS Mm (in.)			WEIGHT Kg (lbs)
		L	W	H	
EW WV100	100 (220)	1330 (52)	830 (33)	1015 (40)	450 (992)
EW DCP250	250 (551)	1680 (66)	1080 (43)	1921 (76)	850 (1874)
EW DCP500	500 (1102)	2230 (88)	1174 (46)	1982 (78)	1200 (2646)
EW DCP700	700 (1543)	2400 (94)	1200 (47)	2050 (81)	1600 (3527)
EW DCP1000	1000 (2205)	2700 (106)	1270 (50)	2120 (83)	2100 (4630)

## Required Clearances

Top : 400mm (16 in.) for lid up  
 Sides : 584.2mm (23 in.) compost cabinet  
 Back : 152mm (6 in.) air exhaust  
 Front : 762mm (30 in.) front panel removal

## Electrical Requirement

- 220 / 415 Volts
- 50 / 60 Hz
- 50 / 60 Amps
- 3 ph w / ground

*Continuing product improvement may subject specifications to change without notice.*



## ECO-WIZ GROUP PTE LTD

No.1 Bukit Batok Crescent WCEGA Plaza #09-58 Singapore 658064

T. +65 6570 0500 F. +65 6570 0900

[www.eco-wiz.com](http://www.eco-wiz.com)